

Mobilier

support chromé crochet poche à urine

REF 45 500 50 = ①

REF 45 500 51 = ②

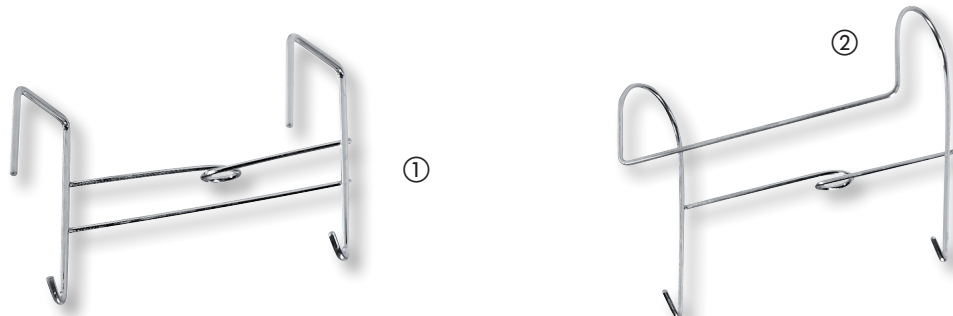

	support chromé poche à urine	chromiumplated urin bag holder	Urinbeutelhalter mit Chromschicht	verchromde urinezakhouder	soporte cromado para bolsa de orina	suporte de saco de urina cromado	supporto per sacchetto urine cromato
①	carré	squared	quadratisch	vierkant	cuadrado	quadrado	squadrato
②	arrondi	rounded	rund	rond	redondeado	arredondado	arrotondato

support plastique crochet poche à urine

REF 45 500 50R = ①

REF 45 500 51R = ②



	support plastique poche à urine	laminated urin bag holder	Laminiertes Urinbeutelhalter	gelamineerde urinezakhouder	soporte laminado para bolsa de orina	suporte de saco de urina laminado	supporto per sacchetto urine laminato
①	carré	squared	quadratisch	vierkant	cuadrado	quadrado	squadrato
②	arrondi	rounded	rund	rond	redondeado	arredondado	arrotondato

panier porte-sérum plastifié

REF 45 400 25R = 250 ml ①

REF 45 400 50R = 500 ml ②

REF 45 400 99R = 1000 ml ③

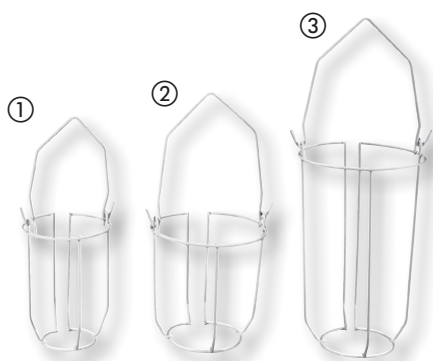

	panier porte serum plastifié	laminated infusion basket	laminiertes Infusionskorb	gelamineerde infuuskorf	soporte laminado para gotero	cesto porta soro laminado	cestello flebo laminato

porte bassin de lit mural

REF 45 500 05



Livré avec 2 vis et 2 chevilles

Supplied with 2 screws and 2 dowels.

Compatible avec nos références :

Compatible with our references :

- 16 200 21
- 16 200 21D
- 16 200 21E

porte bassin de lit mural	wall mount rack	Bettpfannenträger	urinezakhouder voor bedden tegen de muur	soporte laminado para cuña	suporte de arrastadeira laminado	supporto padella da parete

porte urinal plastifié

REF 45 500 00R = ①

REF 45 500 00S = ②



Compatible avec nos références :

Compatible with our references :

- 16 200 22
- 16 200 22C
- 16 200 23

porte urinal plastifié	laminated urinal holder	laminiertes Urinalflaschenhalter	gelamineerde urinaalhouder	soporte laminado para orinal	suporte de urinal laminado	supporto pappagallo laminato
① avec bouchon	with cap	mit Verschluss	met afsluitdop	con tapa	com tampa	con tappo
② sans bouchon	without cap	ohne Verschluss	zonder afsluitdop	sin tapa	sem tampa	senza tappo

porte urinal epoxy

REF 45 500 00



Compatible avec nos références :

Compatible with our references :

- 16 200 23
- 16 200 22

porte urinal epoxy	epoxy urinal holder	Epoxy Urinalflaschenhalter	urinaalhouder uit epoxy	soporte epoxi para urinal	suporte de urinal epoxi	supporto pappagallo epossidico

porte redon epoxy

REF 45 500 10



porte redon epoxy	epoxy redon holder	Epoxy-Redonträger	houder uit epoxy van redon	soporte epoxi para gotero	suporte de redon epoxi	supporto redon epossidico

Mobilier

Tous nos pieds à sérum inox sont fabriqués en tube INOX 18/10 de \varnothing 30 mm d'une longueur de 1000 mm pour la partie support et de \varnothing 16 mm d'une longueur de 1200 mm pour la partie coulissante.

La hauteur maximale autorisée est de 2100 mm avec un poids maximum de 2 kg par crochet.

Our range of infusion feet is made of 18/10 STAINLESS STEEL \varnothing 30 mm and length 1.000 mm for the bottom part and \varnothing 16 mm and length 1.200 mm for the top part.

Maximum height = 2.100 mm with a maximum weight of 2 kg for each hook.

pied à sérum inox base plastique



REF 45 400 05 = ①

REF 45 404 05 = ②

REF 45 410 05 = ③

REF 45 410 06 = ④



	pied à sérum base plastique	plastic base infusion foot	Kunststoff-Fuß für Infusionsständer	plastic basis voor infuushouder	soporte de gotero con base de plástico	pedestal de soro base de plástico	piantana da flebo con base in plastica
①	2 crochets plastiques	2 plastic hooks	2 Plastikhaken	2 plastic haken	2 ganchos de plástico	2 ganchos de plástico	2 ganci in plastica
②	4 crochets plastiques	4 plastic hooks	4 Plastikhaken	4 plastic haken	4 ganchos de plástico	4 ganchos de plástico	4 ganci in plastica
③	2 crochets inox	2 stainless steel hooks	2 Edeltstahlhaken	2 haken uit roestvrij staal	2 ganchos de acero inoxidable	2 ganchos de aço inox	2 ganci in acciaio inox
④	4 crochets inox	4 stainless steel hooks	4 Edeltstahlhaken	4 haken uit roestvrij staal	4 ganchos de acero inoxidable	4 ganchos de aço inox	4 ganci in acciaio inox

pied à sérum inox base aluminium



REF 45 416 02 = ①

REF 45 416 04 = ②



	pied à sérum base aluminium	aluminium base infusion foot	Aluminium-Fuß für Infusionsständer	aluminium basis voor infuushouder	soporte de gotero con base de aluminio	pedestal de soro base de aluminio	piantana da flebo con base in alluminio
①	2 crochets inox	2 stainless steel hooks	2 Edeltstahlhaken	2 haken uit roestvrij staal	2 ganchos de acero inoxidable	2 ganchos de aço inox	2 ganci in acciaio inox
②	4 crochets inox	4 stainless steel hooks	4 Edeltstahlhaken	4 haken uit roestvrij staal	4 ganchos de acero inoxidable	4 ganchos de aço inox	4 ganci in acciaio inox

ped à sérum acier laqué blanc

REF 45 420 02B = ①

REF 45 420 04B = ②



	<i>ped à sérum laqué blanc</i>	<i>lacquered plastic base infusion foot</i>	<i>Lackierter Fuß für Infusionsständer</i>	<i>gelakte plastic basis voet infuushouder</i>	<i>soporte de gotero con base de plástico lacado</i>	<i>pedestal de soro base laminada</i>	<i>piantana da flebo con base in plastica laccata</i>
①	2 crochets plastiques	2 plastic hooks	2 Plastikhaken	2 plastic haken	2 ganchos de plástico	2 ganchos de plástico	2 ganci in plastica
②	4 crochets plastiques	4 plastic hooks	4 Plastikhaken	4 plastic haken	4 ganchos de plástico	4 ganchos de plástico	4 ganci in plastica

tige

REF 4540005T = ①

REF 4541005T = ②

REF 4541006T = ③

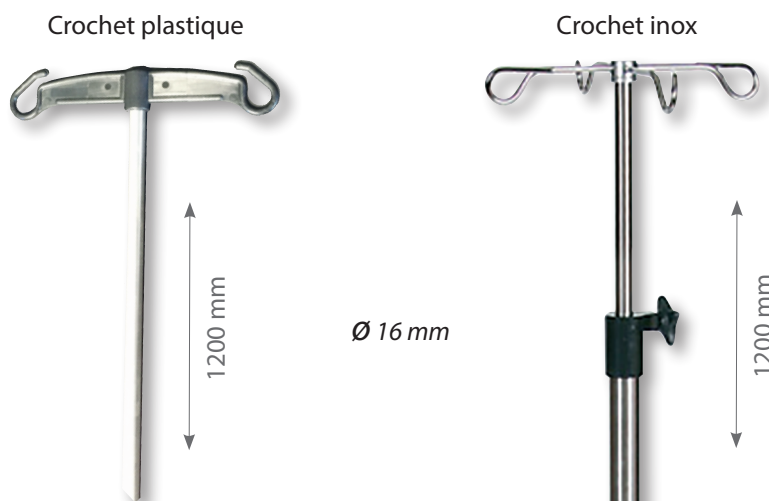

	<i>tige</i>	<i>stem</i>	<i>Hängevorrichtung</i>	<i>poot</i>	<i>varilla</i>	<i>barra</i>	<i>stelo</i>
①	2 crochets plastiques	2 plastic hooks	2 Plastikhaken	2 plastic haken	2 ganchos de plástico	2 ganchos de plástico	2 ganci in plastica
②	2 crochets inox	2 stainless steel hooks	2 Edelstahlhaken	2 haken uit roestvrij staal	2 ganchos de acero inoxidable	2 ganchos de aço inox	2 ganci in acciaio inox
③	4 crochets inox	4 stainless steel hooks	4 Edelstahlhaken	4 haken uit roestvrij staal	4 ganchos de acero inoxidable	4 ganchos de aço inox	4 ganci in acciaio inox

plateau pour pied à sérum

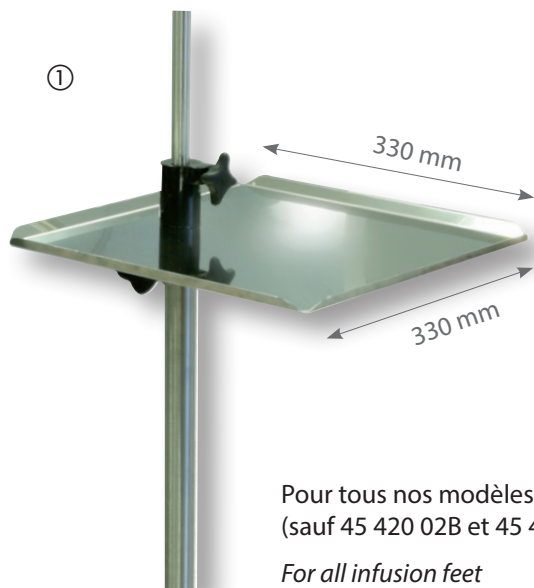

①

Pour tous nos modèles de pieds à sérum
(sauf 45 420 02B et 45 420 04B).

*For all infusion feet
(except 45 420 02B and 45 420 04B).*

②

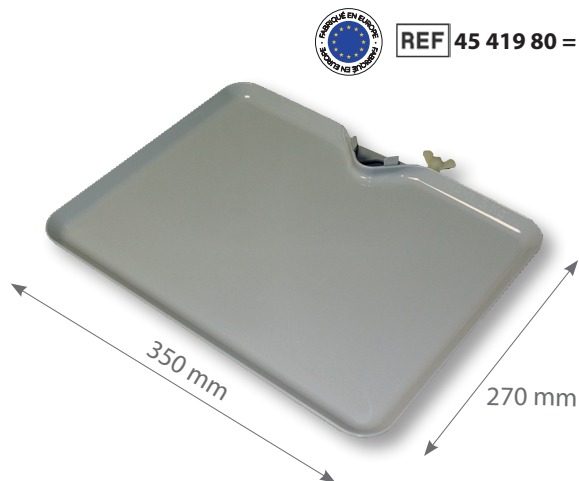

REF 45 419 90 = ①

REF 45 419 80 = ②

Compatible avec tous nos modèles
de pieds à sérum.

For all infusion feet.

	plateau pour pied à sérum	tray for infusion foot	Tablett für Infusionsständer	schaal voor infuushouder	bandeja para soporte de gotero	tabuleiro para pedestal de soro	vassoio per piantana da flebo
①	inox	stainless steel	Edelstahl	roestvrij staal	acero inoxidable	aço inoxidável	acciaio inossidabile
②	plastique	plastic	Plastik	Kunststoff	plástico	plástico	plastica

alourdisseur pour pied à sérum

REF 45 419 95 = 2 kg

REF 45 419 97 = 5 kg



Pour tous nos modèles de pieds à sérum (sauf Medicafoot).

Weight for all infusion feet (except Medicafoot).

	alourdisseur pour pied à sérum	weight for infusion foot	Gewicht für Infusionsständer	gewicht voor infuushouder	peso para soporte de gotero	peso para pedestal de soro	peso per piantana da flebo

fiches médicales "Stern-Org"

REF 45 002 50 = 15,1 x 21 cm

REF 45 002 60 = 12,5 x 20 cm

x 250

Fiches 3 volets.

3 portions card.



fiches médicales "Stern-Org"	medical cards "Stern-Org"	Karteikarten "Stern-Org"	medische kaarten "Stern-Org"	fichas médicas "Stern-Org" en Francès	fichas médicas "Stern-Org"	schede mediche "Stern-Org"

suites de fiches médicales "Stern-Org"

REF 45 002 51 = 14,9 x 21 cm (for 42 002 50)

REF 45 002 61 = 12,4 x 19,7 cm (for 42 002 60)



x 250

Fiches 1 volet.

1 portion card.



suites de fiches médicales "Stern-Org"	medical cards "Stern-Org"	Folgekarten "Stern-Org"	pak medische kaarten "Stern-Org"	juego de fichas médicas "Stern-Org"	fichas médicas de continuação "Stern-Org"	serie di schede mediche "Stern-Org"

lampe loupe

REF 45 350 10



Tube fluorescent de 22 W. Loupe de 5 dioptries ø 12 cm.
Livrée avec alourdisseur 5 kg.
Pied sur roulettes avec frein.

Strong light of 22 W. Magnifying glass
of 5 dioptries and ø 12 cm. Wheels foot with brake.
Delivered with weight of 5 kg.

lampe loupe	lamp with magnifying glass	Lampe mit Vergrößerungsglas	lamp met vergroot-glas	lámpara con lupa	lâmpada com lupa	lampada con lente d'ingrandimento